

6925
PESO TEORICO 0.284 KG/M
PERIMETRO 0.235 MTS

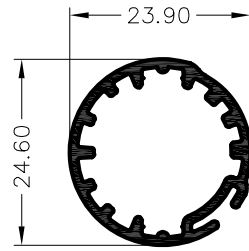

6926
PESO TEORICO 0.294 KG/M
PERIMETRO 0.190 MTS

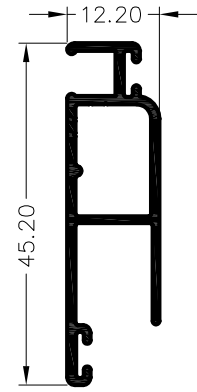

6927
PESO TEORICO 0.316 KG/M
PERIMETRO 0.222 MTS

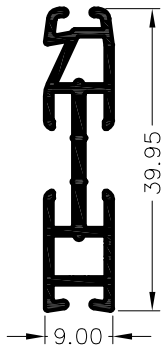

6928
PESO TEORICO 0.343 KG/M
PERIMETRO 0.229 MTS

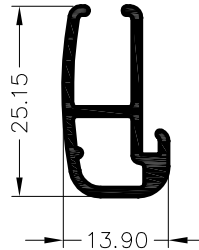

6930
PESO TEORICO 0.248 KG/M
PERIMETRO 0.145 MTS

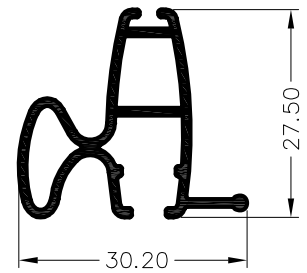

6931
PESO TEORICO 0.340 KG/M
PERIMETRO 0.241 MTS

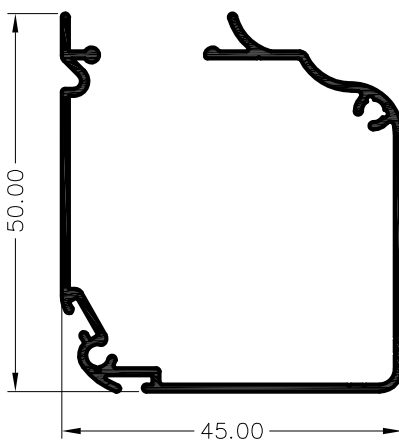

6929
PESO TEORICO 0.486 KG/M
PERIMETRO 0.369 MTS

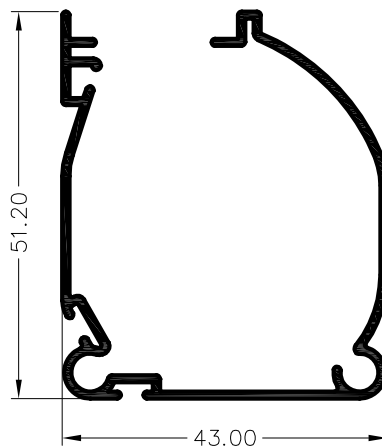

6932
PESO TEORICO 0.493 KG/M
PERIMETRO 0.378 MTS

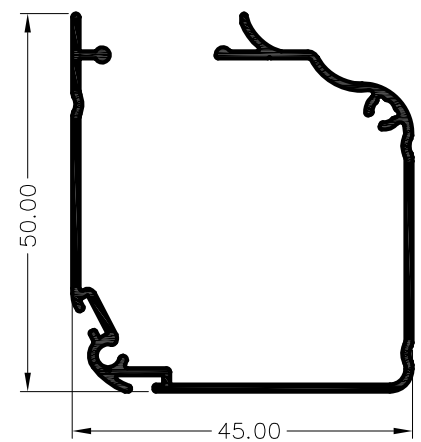

6949
PESO TEORICO 0.485 KG/M
PERIMETRO 0.366 MTS

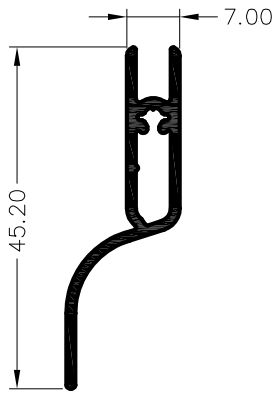

6933
PESO TEORICO 0.279 KG/M
PERIMETRO 0.166 MTS

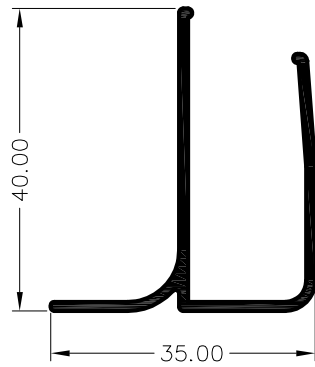

6934
PESO TEORICO 0.351 KG/M
PERIMETRO 0.213 MTS

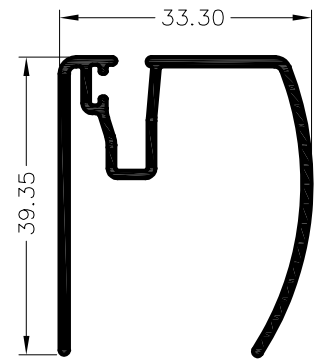

6935
PESO TEORICO 0.432 KG/M
PERIMETRO 0.281 MTS

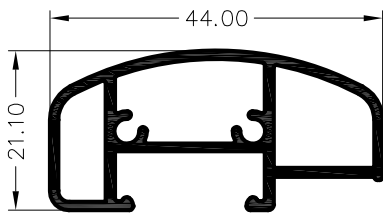

6936
PESO TEORICO 0.483 KG/M
PERIMETRO 0.306 MTS

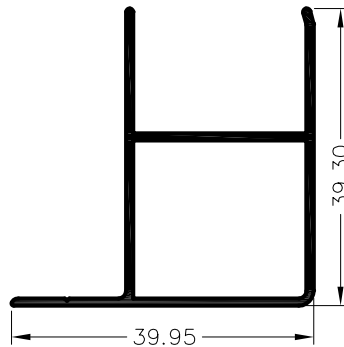

6938
PESO TEORICO 0.355 KG/M
PERIMETRO 0.277 MTS

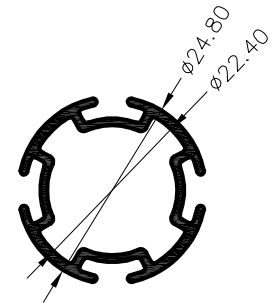

6939
PESO TEORICO 0.294 KG/M
PERIMETRO 0.206 MTS

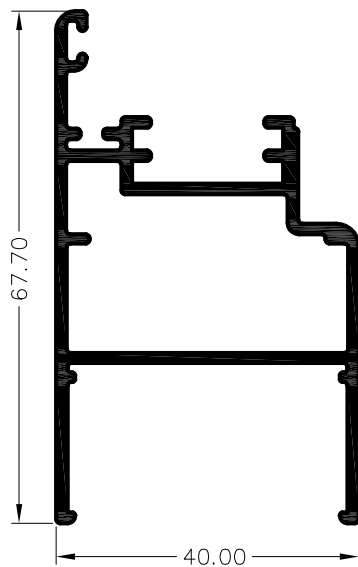

6937
PESO TEORICO 0.878 KG/M
PERIMETRO 0.451 MTS

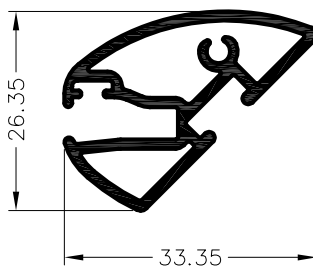

6940
PESO TEORICO 0.452 KG/M
PERIMETRO 0.267 MTS

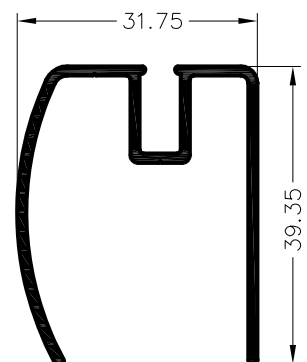

6941
PESO TEORICO 0.415 KG/M
PERIMETRO 0.257 MTS

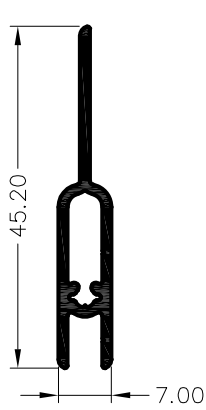

6942	
PESO TEORICO	0.266 KG/M
PERIMETRO	0.155 MTS

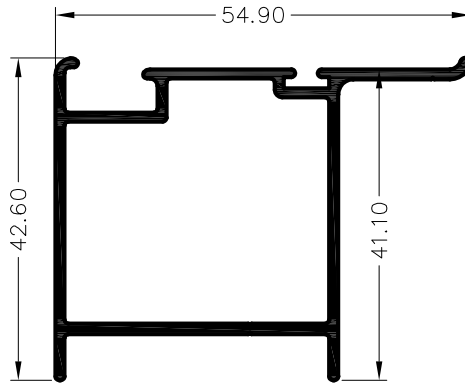

6943	
PESO TEORICO	0.626 KG/M
PERIMETRO	0.365 MTS

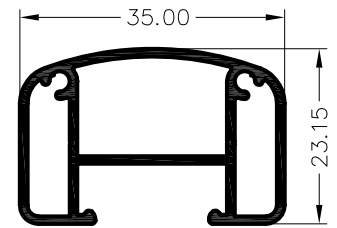

6944	
PESO TEORICO	0.421 KG/M
PERIMETRO	0.298 MTS

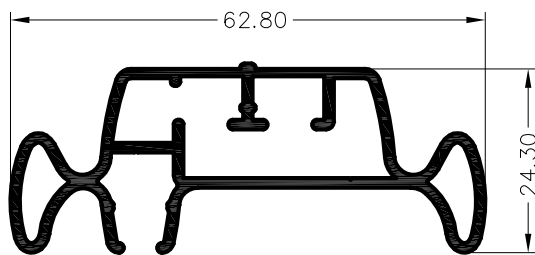

6945	
PESO TEORICO	0.748 KG/M
PERIMETRO	0.437 MTS

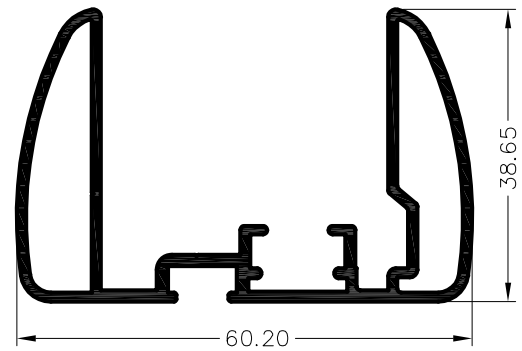

6946	
PESO TEORICO	0.826 KG/M
PERIMETRO	0.484 MTS

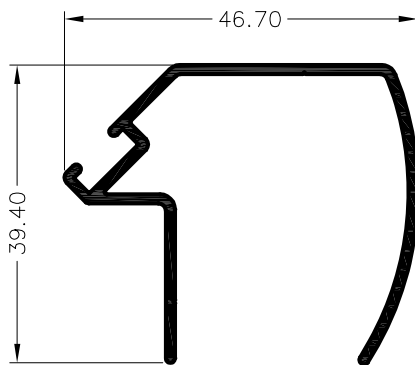

6947	
PESO TEORICO	0.423 KG/M
PERIMETRO	0.262 MTS

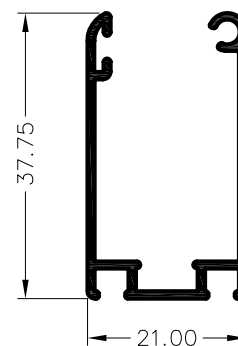

6948	
PESO TEORICO	0.298 KG/M
PERIMETRO	0.234 MTS

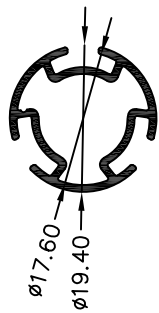

6951
PESO TEORICO 0.204 KG/M
PERIMETRO 0.163 MTS

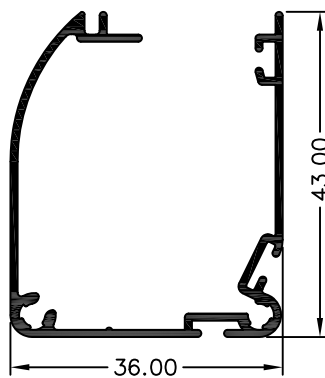

6952
PESO TEORICO 0.438 KG/M
PERIMETRO 0.321 MTS

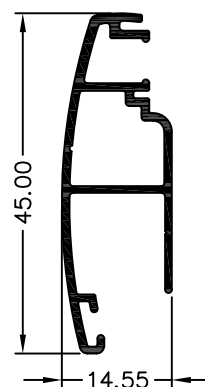

6953
PESO TEORICO 0.315 KG/M
PERIMETRO 0.230 MTS

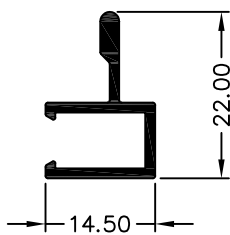

1611
PESO TEORICO 0.191 KG/M
PERIMETRO 0.102 MTS